



BURGLAR ESTABLISHED 1981
& FIRE ALARM

ASSOCIATION OF MICHIGAN

APPRENTICESHIP PROGRAM

Period 1
Related Training Instruction (RTI)
Module 3 – Fire Alarm Signaling Systems

Reading material associated with this module:
Chapters 5 and 6
Fire Alarm Signaling Systems, Fourth Edition 2010

Chapter 5 – Components and Circuits

Fire Alarm Control Units:

- The basic components of a fire alarm system include notification devices, automatic fire detectors, manual fire alarm boxes, waterflow alarm-initiating devices or other alarm-initiating devices connected to a fire alarm control unit (FACU) using circuits described as notification appliance circuits (NAC), initiating-device circuits (IDC) and signaling-line circuits (SLC).
- The FACU is designed to be the central operating point of any fire alarm system. Types can range from conventional to addressable or addressable/analog, each providing different features that may or may not be necessary based on the design of the system.

Chapter 5 – Components and Circuits

Fire Alarm Control Units - Conventional:

- Conventional FACU's are typically designed to accept initiating devices that provide either normal or alarm status information. Additional information, such as exact location (point ID) or alarm threshold levels are not provided.
- The devices are typically arranged in a zone, such as all of the devices on a floor, and when an alarm condition occurs, the zone in alarm will be reported at the FACU. Conventional systems are used when detailed information regarding detector status or location is not critical to report.
- Typical applications for conventional systems include small stores, office buildings and storage facilities.
- Additional requirements imposed by the State of Michigan Building Code further restrict the areas where conventional FACUs and devices may be utilized because of the inability to provide distinct device identification and location information. (2021 MBC Section 907.6.3)

Chapter 5 – Components and Circuits

Fire Alarm Control Units – Addressable:

- In larger systems, more information is needed or desired from the fire alarm system. This information could be as basic as tracking the history and exact location of the detectors reporting.
- This additional information can enable:
 - The fire ground commander to track the location and progression of the fire.
 - A technician to efficiently locate the source of a system problem or false alarm.
- The initiating device is still basically an on/off device, but its on/off status and exact location are transmittable to the addressable FACU.

Chapter 5 – Components and Circuits

Fire Alarm Control Units – Addressable/Analog:

- In order to utilize the addressable features of new microprocessor-based FACUs, and to improve the performance and reliability of system-connected smoke detectors, the analog/addressable system was developed.
- Addressable/analog devices report their exact location and alarm threshold status.
- This allows the FACU to monitor how clean/dirty a smoke detector is and request service on the detector prior to nuisance alarms.
- Additionally, utilizing an addressable/analog FACU, each individual smoke detector response level can be set to take into consideration the environmental conditions in the detector's location.

Chapter 5 – Components and Circuits

Fire Alarm Control Units – Low-Power Radio (Wireless):

- FACU's may utilize wireless initiating and/or indicating devices, particularly when it is difficult to route wiring to the device locations. Typical applications include:
 - Historic buildings.
 - Industrial buildings that use corrosive materials that may affect the system wiring.
 - Buildings that are remote from the main building.
- Wireless initiating devices provide individual device reporting to a receiver unit.
- Wireless indicating devices may be audible and/or visual.
- Wireless devices are typically powered by a dry cell battery, that will transmit a low battery condition.
- In commercial applications, devices are equipped with a tamper switch to generate a signal if the device is removed from its installed location.
- NFPA 72 Section 23.16 covers the special requirements for these systems.

Chapter 5 – Components and Circuits

Power Supply Requirements for Fire Alarm Systems:

- Regardless of the type of fire alarm system, NFPA 72 specifies similar requirements for fire alarm system power supplies. Each power supply must have adequate capacity for the application.
- A fire alarm system is traditionally required to have a primary (main) and secondary power supply. Beginning with the 2010 edition of NFPA 72, a new provision was included allowing the use of an uninterruptible power supply (UPS) instead of both primary and secondary power supplies.
- **Uninterruptible Power Supply (UPS):** The UPS must conform to the requirements of NFPA 111, *Standard on Stored Electrical Energy Emergency and Standby Power Systems* for a Type 0, Class 24, Level 1 system.
 - Type 0 means that there is no delay of power output if the supply of normal power to the UPS is interrupted.
 - Class 24 means that the UPS must be capable of providing power for a period of 24 hours on interruption of normal power to the UPS.
 - Level 1 refers to the minimum installation, performance, and testing requirements specified in NFPA 111.

Chapter 5 – Components and Circuits

Power Supply Requirements for Fire Alarm Systems:

- ***Uninterruptible Power Supply (UPS) (continued):***
 - The requirements for a Level 1 systems are more rigorous than for a Level 2 system.
 - The UPS must be connected to a dedicated branch circuit and be supplied in the same way as would be required for a primary (main) power supply.
 - The integrity of the power supply must be monitored, and a trouble signal generated on failure of the power supply or failure of the UPS.
- ***Primary (Main) Power Supply:***
 - The primary (main) power supply may be provided by commercial light and power or an engine driven generator.
 - One phase of a three-wire or two-wire supply.
 - Must be on a dedicated branch circuit.
 - The disconnecting means must be marked “FIRE ALARM CIRCUIT”.

Chapter 5 – Components and Circuits

Power Supply Requirements for Fire Alarm Systems:

- **Primary (Main) Power Supply (continued):**
 - Accessible only to authorized personnel.
 - The location of the dedicated branch circuit disconnecting means must also be permanently identified at the control unit and protected against physical damage.
 - Primary (main) power supply provided by an engine-driven generator must consist of:
 - An engine-driven generator with a trained operator on duty 24 hours a day.
 - **Or** an engine-driven generator or equivalent arranged for cogeneration with commercial light and power with a trained operator on duty 24 hours a day.
 - The integrity of the primary power supply must be monitored, with any failure indicated by a distinctive trouble signal.

Chapter 5 – Components and Circuits

Power Supply Requirements for Fire Alarm Systems:

- ***Secondary Power Supply for Protected-Premises Systems:***
 - The secondary power supply shall provide power to the complete system within 10 seconds in the event of power supply failure or whenever the primary power supply fails to provide the minimum voltage required (typically below 80 percent of the nameplate voltage) for proper operation. The requirement is 60 seconds for supervising station facilities and equipment.
 - The secondary power supply shall have sufficient capacity to operate the system during normal non-alarm condition for 24 hours and for 5 minutes of alarm operation at the end of the 24-hour period.
 - In-building fire emergency voice/alarm communications systems are required to have 24 hours of standby during normal operation and 15 minutes of emergency operation at maximum connected load.

Chapter 5 – Components and Circuits

Power Supply Requirements for Fire Alarm Systems:

- ***Acceptable Sources of Standby Power (Protected Premises):***
 - A storage battery dedicated to the fire alarm system.
 - An automatic-starting engine-driven generator and a dedicated storage battery with 4 hours of capacity.
- ***Acceptable Sources of Standby Power (Supervising Station):***
 - A storage battery dedicated to the fire alarm system.
 - An automatic-starting engine-driven generator and a dedicated storage battery with 4 hours of capacity.
 - A dedicated branch circuit of multiple engine-driven generators, at least one of which is arranged for automatic starting.

Chapter 5 – Components and Circuits

Notification Appliance Power Supplies:

- NFPA requirements for remotely located control equipment, including notification appliance circuit power extenders, must comply with the same power requirements as for the FACU, including primary and secondary power supplies and requirements for monitoring of power supplies.
- The location of any remotely located power supplies must be identified at the master FACU and on the record drawings.

Chapter 5 – Components and Circuits

Standby Battery Calculations:

- The amount of battery standby required can be calculated based on the power requirements of the devices and equipment provided.
- Most manufacturers provide worksheets or software to simplify these calculations.
- Battery capacity diminishes based on age and environmental factors such as temperature. As a minimum, a correction factor of 1.25 shall be applied to these calculations to address this issue and ensure the battery has adequate power at the end of its service life.
- Example:
 - A calculated battery load requires 6.85AH, which would allow for 7AH batteries to be provided.
 - However, applying the 1.25 correction factor, gives a requirement of 8.56AH, which would require larger batteries.

Chapter 5 – Components and Circuits

Monitoring of Power Supplies, Systems Circuits, and Equipment:

- Monitoring the integrity of fire alarm system power supplies, system circuits, and equipment, is critical to system operation and includes the automatic detection of degraded power conditions, circuit faults, and other conditions, which will activate a trouble signal.
- This section describes the components of systems that should be monitored, the individual circuit and system approaches to monitoring, and the relation of device circuits to the fire alarm system.
- To eliminate the confusion between *supervision* and *supervisory*, NFPA 72 uses the term *monitoring integrity of the installation conductors* to reference the supervision of the system wiring.
 - A *trouble signal* is required to sound on the occurrence of a single open or single ground condition.
 - In contrast, a *supervisory signal* indicates the off-normal condition of some part of a sprinkler or other type fire protection system.

Chapter 5 – Components and Circuits

Monitoring of Power Supplies, Systems Circuits, and Equipment (continued):

- Monitoring the integrity of installation conductors involves the automatic detection of faults, such as a single open or a single ground that would prevent normal operation. The condition is automatically transmitted and indicated at the appropriate location.
- Use of double-loop circuits or multiple-path conductors instead of monitoring for integrity is not permitted.

Chapter 5 – Components and Circuits

Monitoring of Power Supplies, Systems Circuits, and Equipment (continued):

- **Power Supply Monitoring:**

- All sources of power (power supplies) in a fire alarm systems must be monitored, except as follows:
 - A power supply for supplementary devices and appliances whose failure will not prevent system operation and alarm signal initiation.
 - A main power supply in a supervising station, provided the fault condition is obvious to operators on duty.
 - The output of an engine-driven generator that is part of the secondary supply, provided the generator is tested weekly.

Chapter 5 – Components and Circuits

Monitoring of Power Supplies, Systems Circuits, and Equipment (continued):

- **System Circuit Monitoring:**
 - ***Initiating Device Circuits and Signaling Line Circuits:***
 - Installation wiring for all devices or equipment that initiate or transmit signals, either manually or automatically must be monitored.
 - Typical devices include manual fire alarm boxes, heat and smoke detectors, and automatically operated transmitters.
 - Exceptions to the monitoring requirement are as follows:
 - Noninterfering shunt circuits, provided that a fault condition of the shunt wiring does not affect essential operating features of the system.
 - Pneumatic continuous-line-type rate of rise heat detection systems, where the device wiring terminals are connected in parallel across electrically monitored circuits.

Chapter 5 – Components and Circuits

Monitoring of Power Supplies, Systems Circuits, and Equipment (continued):

- **System Circuit Monitoring:**
 - **Audible and Visual Notification Appliance Circuits:**
 - Installation wiring for operating audible and visible notification appliance circuits must be monitored. A short or fault in the notification appliance circuit must be indicated by a trouble signal.
 - An exception to the monitoring requirement is as follows:
 - The circuit of an alarm notification appliance installed in the same room as the FACU, provided that the circuit conductors are installed in conduit or otherwise protected against mechanical injury.

Chapter 5 – Components and Circuits

Monitoring of Power Supplies, Systems Circuits, and Equipment (continued):

- **System Circuit Monitoring:**
 - *Other System Circuits:*
 - All other system circuits must be monitored for integrity except as follows:
 - Trouble signal circuits.
 - Interconnections between listed equipment in a common enclosure.
 - Connections to or between supplementary components, provided a single open, ground, or short-circuit condition of the supplementary equipment or connections does not affect the required operation of the fire alarm system.
 - Interconnections between control equipment enclosures located within 20' of each other, provided conductors are installed in conduit or equivalently protected against physical damage.
 - Conductors for ground detection, provided a single ground does not prevent the required normal operation of the system.

Chapter 5 – Components and Circuits

Monitoring of Power Supplies, Systems Circuits, and Equipment (continued):

- **System Circuit Monitoring:**

- **Other System Circuits:**

- All other system circuits must be monitored for integrity except as follows (continued):
 - Interconnections between a stationary computer and associated computer equipment, provided the interconnecting wiring does not exceed 8' in length, is listed computer/data processing cable as permitted by the NEC, and failure of the cable does not cause failure of the required system functions that are not initiated from the associated computer equipment.
 - Monitoring conductors for a ground-fault condition of communications and transmission channels extending from a supervising station to a subsidiary station or protected premises, provided the channels comply with the requirements for supervising station alarm systems in NPFA 72, the channels are electrically isolated from the fire alarm system by a transmitter, and the single ground fault does not affect the operation of the fire alarm system.

Chapter 5 – Components and Circuits

Monitoring of Power Supplies, Systems Circuits, and Equipment (continued):

- **System Circuit Monitoring:**
 - ***Equipment Monitoring:***
 - Speaker amplifier and tone-generating equipment is monitored for speakers used to produce audible fire alarm signals. An audible trouble signal will result on failure of the audio amplifier and/or tone generating equipment. These components need not be monitored if they are enclosed as integral parts and serve only one listed audible notification appliance.
 - The internal components of alarm-initiating devices and alarm notification appliances are not required to be monitored.

Chapter 5 – Components and Circuits

Circuit/Pathway Performance and Operation:

Note that there may be some variations in the information provided in this section based on the Fire Alarm Signaling Systems, 4th Edition and the information contained in NFPA 72, 2022 Edition.

Circuit/Pathway Performance:

- Pathways (interconnections) are designated as Class A, Class B, Class C, Class D, Class E, Class N, or Class X, based on their performance characteristics.
- Fire alarm system wiring and equipment, including all circuits controlled and powered by the fire alarm system, must be installed in accordance with the requirements of NFPA 72 and the National Electrical Code (NEC), Article 760.
- Except for parts of circuits or equipment that are intentionally and permanently grounded to provide ground-fault detection, noise suppression, emergency ground signaling, and circuit protection grounding, all fire alarm systems must test free of grounds.

Chapter 5 – Components and Circuits

Circuit/Pathway Performance and Operation (continued):

Circuit/Pathway Performance:

- *Class A:*
 - Includes a redundant path.
 - Operational capability continues past a single open.
 - Conditions that affect the intended operation of the path are annunciated.
- *Class B:*
 - It does not include a redundant path.
 - Operational capability stops at a single open.
 - Conditions that affect the intended operation of the path are annunciated.

Chapter 5 – Components and Circuits

Circuit/Pathway Performance and Operation (continued):

Circuit/Pathway Performance:

- *Class C:*
 - It includes one or more pathways where the operational capability is verified via end-to-end communication, but the integrity of individual paths is not monitored.
 - A loss of end-to-end communication is annunciated.
- *Class D:*
 - A pathway is designated Class D when it operates in a fail-safe fashion in which no fault is annunciated, but the intended operation is performed in the event of a pathway failure.
- *Class E:*
 - A pathway is designated Class E when it is not monitored for integrity.

Chapter 5 – Components and Circuits

Circuit/Pathway Performance and Operation (continued):

Circuit/Pathway Performance:

- *Class N:*
 - Includes two or more pathways where operational capability of the primary pathway and a redundant pathway to each device shall be verified through end-to-end communication.
 - A loss of end-to-end communication is annunciated.
 - A single open, ground, short, or combination of faults on one pathway shall not affect any other pathway.
 - Conditions that affect the operation of the primary pathway(s) and redundant pathway(s) shall be annunciated when the system's minimal operational requirements cannot be met.
 - Primary and redundant pathways shall not be permitted to share traffic over the same physical segment.

Chapter 5 – Components and Circuits

Circuit/Pathway Performance and Operation (continued):

Circuit/Pathway Performance:

- *Class X:*
 - Includes a redundant path.
 - Operational capability continues past a single open or short-circuit.
 - Conditions that affect the intended operation of the path are annunciated.
- It is not intended that the classes of circuits be construed as grades. Pathway class designation provides a reference means for system designers in selecting the type of circuit performance that best suits the needs of a particular application.

Class B Initiating-Device Circuit

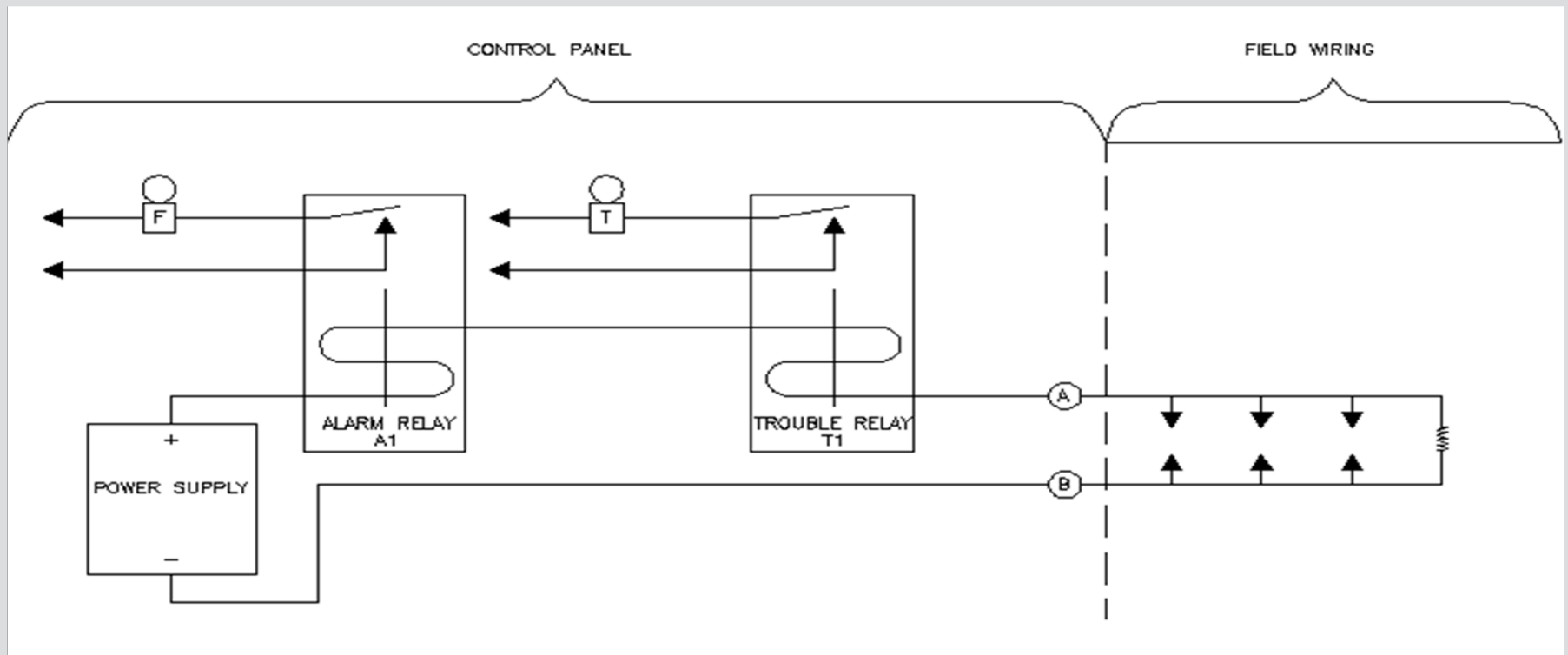

Chapter 5 – Components and Circuits

Circuit/Pathway Performance and Operation (continued):

Initiating-Device Circuit Operation (see previous diagram):

- Class B circuits consist of a two-wire circuit with initiating devices with normally open contacts connected in parallel and terminated with an end-of line resistor.
- The circuitry in the control panel monitors the status of the Class B initiating device circuit conductors.
- During normal operation, a small current flows through the alarm relay and trouble relay (or equivalent solid-state circuit), the field wiring, and end-of-line resistor.
- This small current is enough to keep the trouble relay energized, while not energizing the alarm relay.
- During an alarm condition, the end of line resistor is shunted causing a larger current to flow which is sufficient to activate the alarm relay (or equivalent solid-state circuit) thereby activating the alarm signal.

Chapter 5 – Components and Circuits

Circuit/Pathway Performance and Operation (continued):

Initiating-Device Circuit Operation (continued):

- A short between the wires or a ground fault on both wires will also cause an alarm.
- During a single open trouble condition the small current flow that occurs during normal operation is interrupted and the trouble signal is activated. This condition will also render all initiating-devices that are electrically past the open inoperable.
- When an automatic fire detector has integral trouble contacts (typical with duct smoke detectors), these contacts must be wired between the last detector and the end-of-line resistor to prevent the opening of the trouble contact impairing the alarm operation of other fire detectors (see diagram on next slide).

Class B Initiating-Device w/ Integral Trouble Contacts

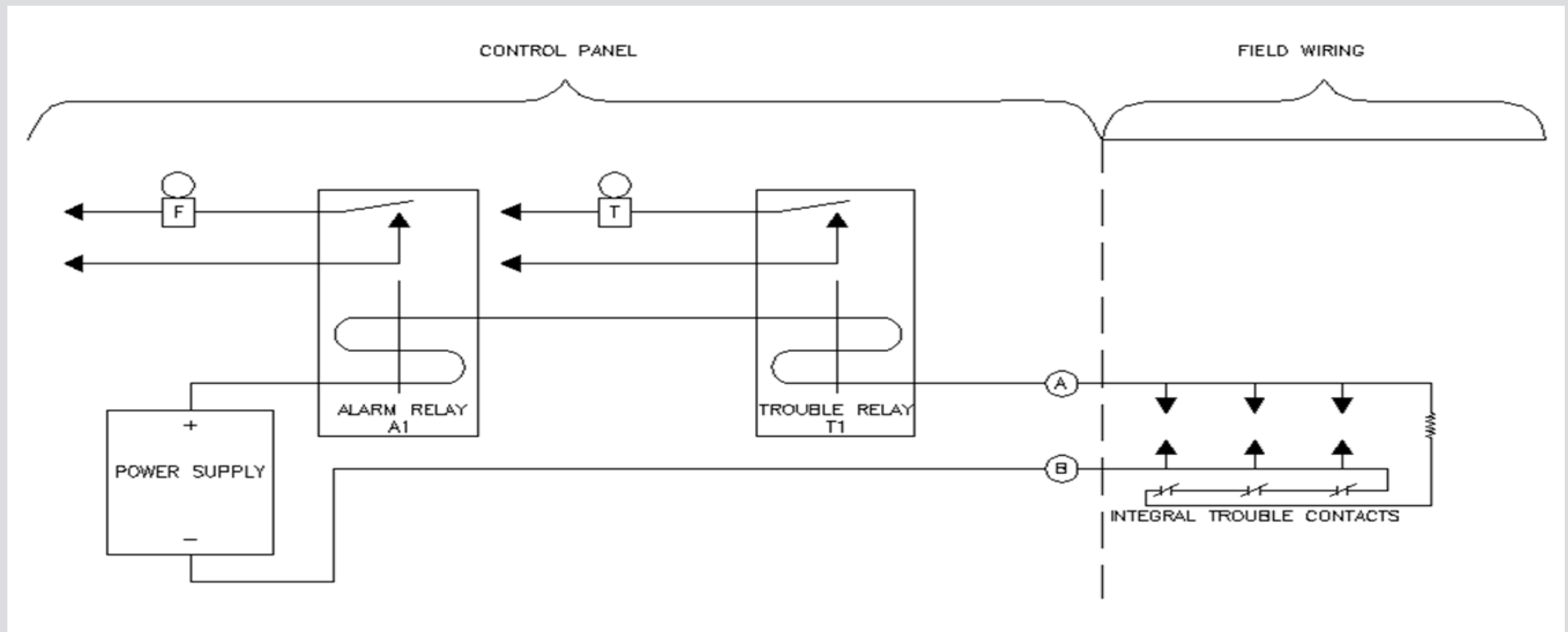

Incorrect Class B Initiating-Device Circuit Wiring

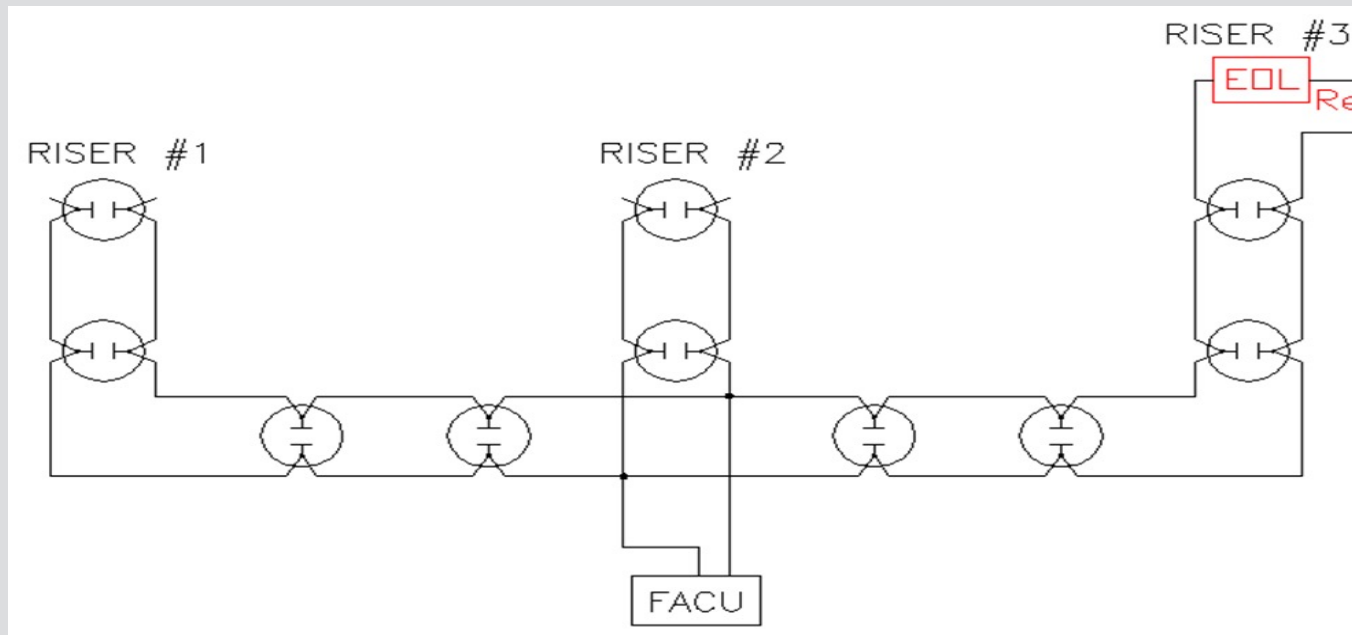

Chapter 5 – Components and Circuits

Circuit/Pathway Performance and Operation (continued):

Initiating-Device Circuit Operation (see previous diagram):

- Special attention must be given to the way an alarm initiating-device circuit is wired in the field to ensure proper supervision.
- In the example shown on the previous slide, an open on riser #1 or riser #2 would not be indicated at the panel and the panel would set up as though it were in the normal (monitored) condition as the supervisory current would still flow through riser #3 and the end-of-line device.
- The correct wiring for a Class B initiating-device circuit is shown in the following slide.
- It is now obvious that a single open in riser #1 or riser #2 will open the circuit and activate the trouble signal.

Correct Class B Initiating-Device Circuit Wiring

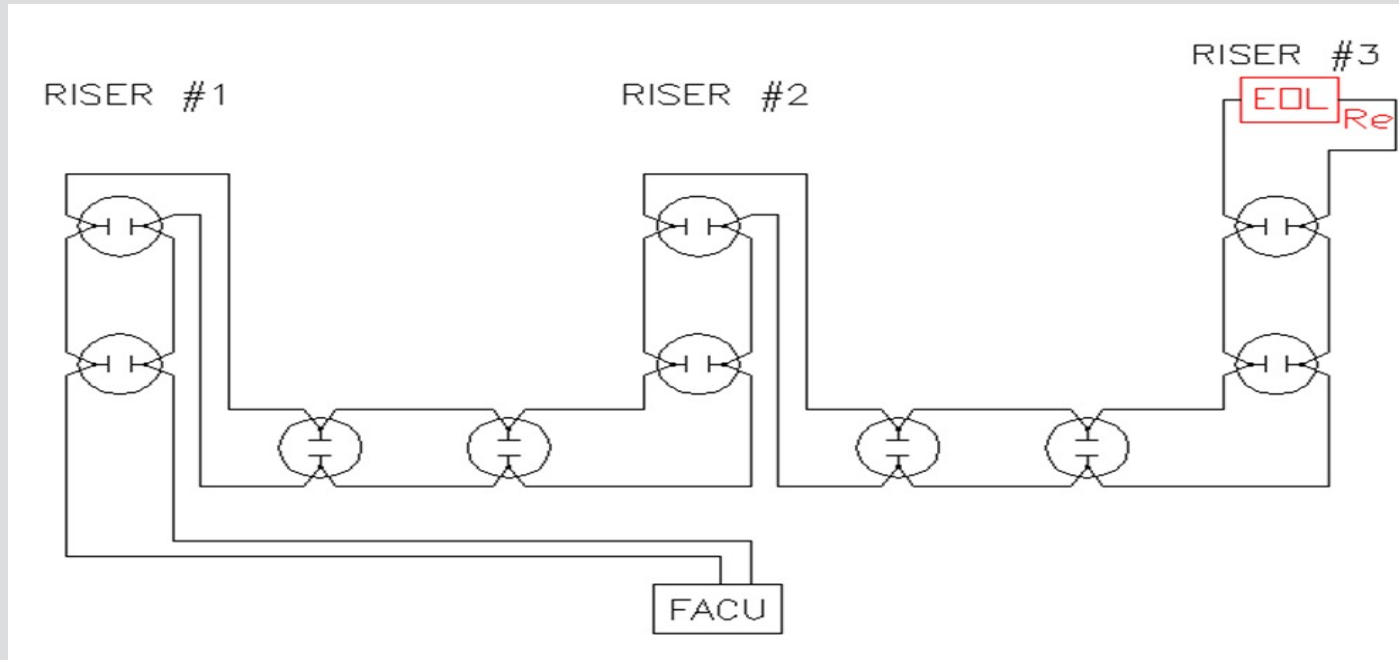

Class A Initiating-Device Circuit

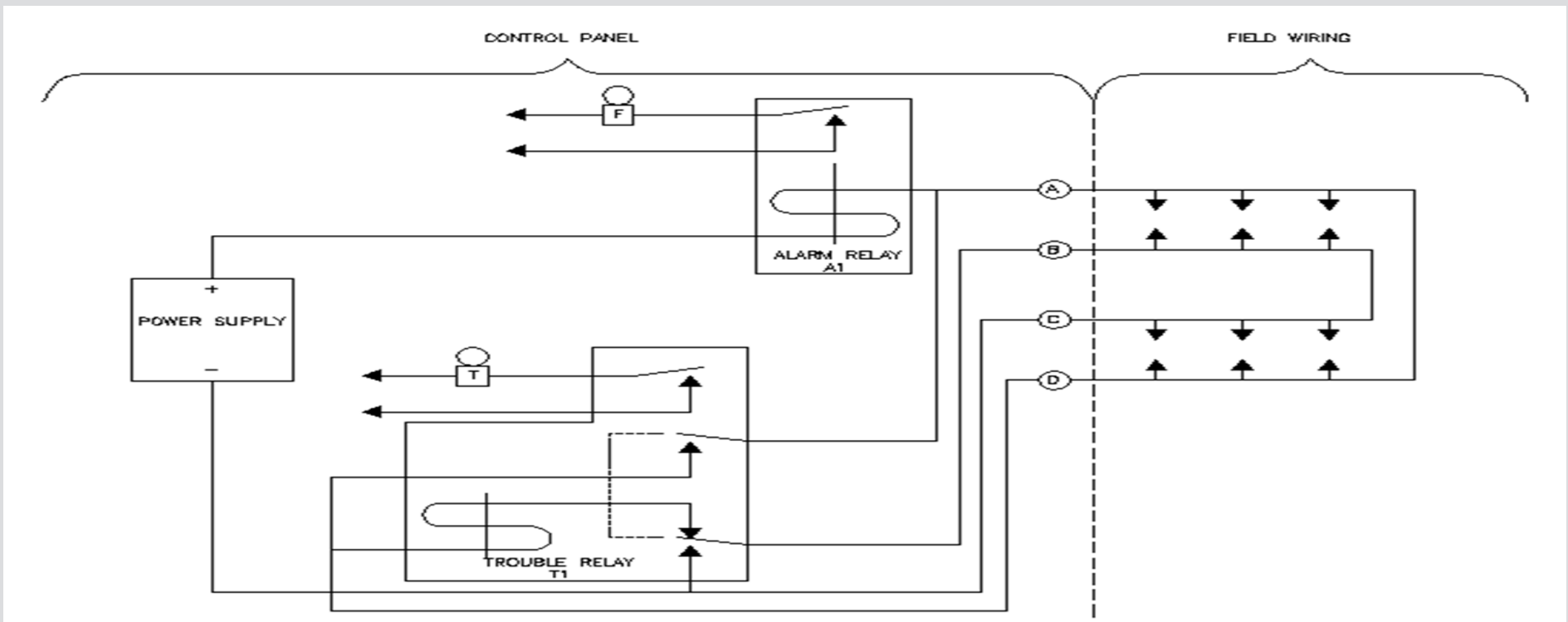

Chapter 5 – Components and Circuits

Circuit/Pathway Performance and Operation (continued):

Initiating-Device Circuit Operation (see previous diagram):

- Class A or X initiating-device circuits consist of a four-wire circuit with initiating devices with normally open contacts connected in parallel with the end-of line resistor located integral to the control unit.
- When a single open fault occurs, the system is designed so that additional relay contacts (or equivalent solid-state circuit) connect terminals A & D, as well as terminals B & C together so that alarm capability is maintained even with the single open fault. The trouble signal is operated.
- If more than one open fault occurs, any devices between the two faults would fail to operate.

Class B Notification Appliance Circuit

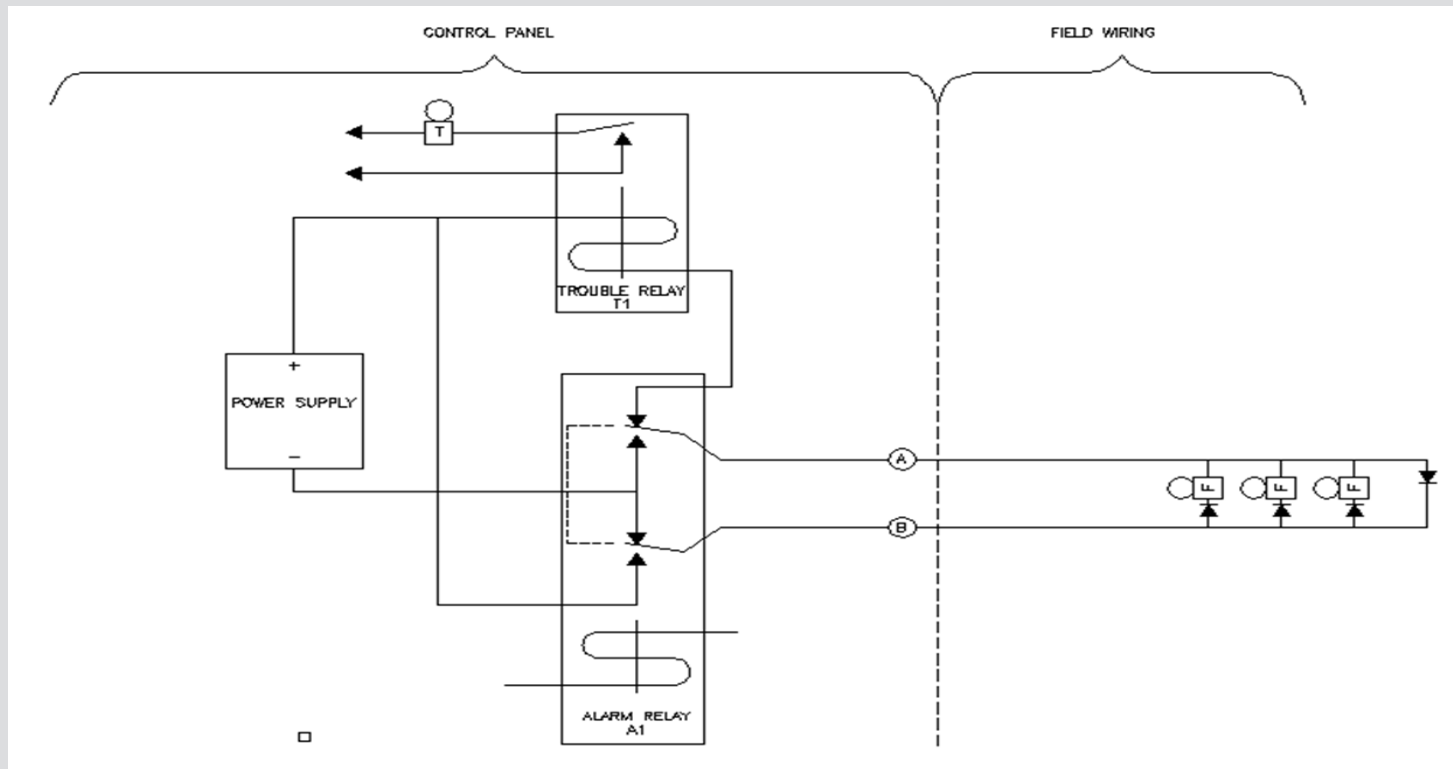

Chapter 5 – Components and Circuits

Circuit/Pathway Performance and Operation (continued):

Notification Appliance Circuits (see previous diagram):

- Notification appliance circuits can also be configured as Class B, Class A, or Class X circuits.
- The Class B notification appliance circuit on the previous slide is shown in normal standby condition.
- A small current flows from the negative power supply terminal out terminal B through the end of line device (in this case a diode), back to terminal A through the trouble relay and returning to the positive power supply terminal. Note the diodes shown in line with each notification appliance. These are typically installed in the device when it is manufactured.

Chapter 5 – Components and Circuits

Circuit/Pathway Performance and Operation (continued):

Notification Appliance Circuits (see previous diagram):

- The purpose of these diodes is to block current during a normal supervisory condition but allow it to pass when the circuit is activated during an alarm condition when the relays change state, which bypasses the trouble relay, and reverses the polarity of the power applied to the field wiring.
- The diodes in line with the notification appliances no longer block the current flow because of the reversed polarity which allows the current to pass through the notification appliances and the appliances to operate.

Chapter 5 – Components and Circuits

Circuit/Pathway Performance and Operation (continued):

Signaling Line Circuits (see previous diagram):

- Signaling line circuits are defined as a circuit path between any combination of addressable appliances or devices, circuit interfaces, control units, or transmitters, over which multiple system input and output signals or both are carried.
- In signaling line circuits, each device on the circuit is provided with an address that is identifiable by the control unit.
- To monitor the integrity of these circuits, the control unit sends out frequent polling signals to each device on the circuit to verify that the control unit is successfully communicating with the equipment on the circuit. A trouble signal is activated if the desired response is not received.
- Signaling line circuits can be configured as Class B, Class A, or Class X circuits.
- The devices are individually addressed, negating the need for an end-of-line device or supervisory current.

Chapter 5 – Components and Circuits

Circuit/Pathway Performance and Operation (continued):

Low-Power Radio (Wireless) Devices:

- The low-power radio transmitter/transceiver shall be specifically listed as using a communication method that is highly resistant to misinterpretation of simultaneous transmissions and to interference.
- The occurrence of any single fault that disables communication between any low-power radio transmitter/transceiver and the receiver/transmitter system control unit shall cause a latching trouble signal within 200 seconds at the system control unit that individually identifies the affected device.
- A single fault on the signaling channel shall not cause an alarm signal.
- Removal of a low-power radio transmitter/receiver from its installed location shall immediately transmit a trouble signal that indicates its removal and the identity of the affected device.

Chapter 5 – Components and Circuits

Circuit/Pathway Performance and Operation (continued):

Low-Power Radio (Wireless) Devices (continued):

- Reception of any unwanted (interfering) transmission by a retransmission device or by the receiver system control unit for a continuous period of 20 seconds or more shall cause a trouble indication at the control unit.
- Radio frequency pathways are designated as either Class A or Class B. This is primarily based on whether a redundant pathway is included (Class A) or not (Class B).

Chapter 5 – Components and Circuits

Circuit or Pathway Survivability:

- The performance description of survivability is described in NFPA 72 as:
“Fire alarm systems used for partial evacuation and relocation shall be designed and installed such that attack by fire within an evacuation signaling zone shall not impair control and operation of the notification appliances outside the evacuation signaling zone.”
- NFPA 72 contains numerous resources for determining survivability requirements, which will be covered in more detail in later sections of the apprenticeship program.
- *Pathway Survivability Level 0:* Level 0 pathways shall not be required to have any provisions for pathway survivability.
- *Pathway Survivability Level 1:* Pathway survivability Level 1 shall consist of pathways in buildings that are fully protected by an automatic sprinkler system in accordance with NFPA 13, *Standard for the Installation of Sprinkler Systems*, with any interconnecting conductors, cables or other physical pathways installed in metal raceways or metal armored cables.

Chapter 5 – Components and Circuits

Circuit or Pathway Survivability:

- *Pathway Survivability Level 2:* Pathway survivability Level 2 shall consist of one or more of the following:
 - 2-hour fire-rated circuit integrity (CI) or fire-resistive cable.
 - 2-hour fire-rated cable system (electrical circuit protective system(s)).
 - 2-hour fire-rated enclosure or protected area.
 - Performance alternatives approved by the authority having jurisdiction.

Chapter 5 – Components and Circuits

Circuit or Pathway Survivability:

- *Pathway Survivability Level 3:* Pathway survivability Level 3 shall consist of pathways in buildings that are fully protected by an automatic sprinkler system in accordance with NFPA 13, *Standard for the Installation of Sprinkler Systems*, and one or more of the following:
 - 2-hour fire-rated circuit integrity (CI) or fire-resistive cable.
 - 2-hour fire-rated cable system (electrical circuit protective system(s)).
 - 2-hour fire-rated enclosure or protected area.
 - Performance alternatives approved by the authority having jurisdiction.

Chapter 6 – Signal Initiation

Introduction:

- Fire alarm signals can be initiated by several types of devices:
 - Manually by fire alarm boxes (pull stations).
 - Automatic actuation initiated by smoke, heat, energy, radiation, and other detectable byproducts of a fire.
 - Combined with fire extinguishing systems.
 - Fire extinguishing systems require supervisory devices to detect abnormal conditions such as valve position, low water pressure, low temperature, or water level changes.
 - Guards tour supervisory service activation.

Chapter 6 – Signal Initiation

Manual Actuated Alarm–Initiating Devices:

- Manual fire alarm boxes are only used for fire protective signaling. Combination stations (guards tour and fire alarm) may be used if so listed.
 - Manual fire alarm boxes are required to be red. Manual boxes may be used for conditions other than fire if differentiated by a color other than red and labeling.
 - Manual boxes must be securely mounted.
 - The operable part of the station shall be not less than 42” nor more than 48” above floor level.
 - Manual fire alarm boxes shall be mounted on a background of contrasting color.
 - Listed protective covers may be installed over single- or double-action boxes.

Chapter 6 – Signal Initiation

Manual Actuated Alarm–Initiating Devices (continued):

- Manual stations shall be unobstructed, readily accessible, and located in the normal path of egress as follows:
 - Manual fire alarm boxes shall be located within 5’ of each exit doorway on each floor.
 - Additional boxes shall be placed so the travel distance to the nearest box will not exceed 200’ measured horizontally on the same floor.

Chapter 6 – Signal Initiation

Manual Actuated Alarm–Initiating Devices (continued):

- Manual stations may be one of four types:
 - Non-coded or coded
 - Pre-signal or general alarm
 - Break-glass or non-break-glass
 - Single- or double-action

Chapter 6 – Signal Initiation

Manual Actuated Alarm–Initiating Devices (continued):

- Non-coded:
 - Contains a switch located in a distinctive enclosure.
 - When actuated, the station contacts transfer.
 - This condition is maintained until the station is reset to normal condition.
- Coded:
 - Contains a mechanically or electrically driven motor which, when activated, turns a code wheel to momentarily open and close contacts to reproduce the coded signal.
 - Code must be repeated a minimum of three times.
 - Boxes may be surface, flush, or semi-flush mounted.

Chapter 6 – Signal Initiation

Manual Actuated Alarm–Initiating Devices (continued):

- Pre-signal:
 - Initially causes an alarm signal to sound only in specific areas, such as a department offices, control rooms, fire brigade stations, or other constantly attended locations.
 - Must transmit to a remote station, if so connected, immediately upon the initial alarm signal.
- General alarm:
 - General alarm is the most common operation.
 - Evacuation signal sounds immediately.

Chapter 6 – Signal Initiation

Manual Actuated Alarm–Initiating Devices (continued):

- Break-glass:
 - Actuation of the station will be preceded by breaking a glass rod or other breakable element.
 - The purpose is to deter false alarms, and satisfy the requirement that the, once activated, the station cannot be reset without the use of a special tool.
 - Initially provided with a glass plate that would require a hammer (attached to the station) to break the glass and actuate the station, although the hammers were frequently missing.
 - There have also been issues with glass rods being replaced with a non-breakable material which resulted in a station being non-operable.
- Non-break-glass:
 - All stations without this feature are considered non-break-glass.

Chapter 6 – Signal Initiation

Manual Actuated Alarm–Initiating Devices (continued):

- Single-action:
 - A single-action station only requires one action by the user to initiate an alarm signal, usually through breaking a glass element or actuating a lever or other movable part of the station.
- Double-action:
 - A double-action station initiates an alarm based on two actions taken by the user.
 - Typically, the initial action can include breaking a glass element, opening a door, or lifting a cover to gain access to a lever or switch, which then must be operated to initiate an alarm.
 - These types of stations are thought to reduce the incidence of inadvertent actuation.

Chapter 6 – Signal Initiation

Automatic Fire Detectors:

- Automatic fire detectors mimic the human senses to detect the environmental changes created by a fire. The most common elements of a fire that can be detected are:
 - Heat
 - Smoke (aerosol)
 - Gas
 - Light radiation
- Not all fires produce all of these elements and non-fire conditions can produce similar conditions.
- The design of the fire alarm system should take into account the elements that might be expected from a fire in a particular space and involving specific combustibles and ignition sources, as well as ambient conditions that might result from non-fire situations.

Chapter 6 – Signal Initiation

Automatic Fire Detectors (continued):

- Heat detectors can be classified as responsive to an abnormally high heat condition or an excessive rate of temperature rise.
- Smoke (aerosol) detectors are sensitive to particles of combustion.
- Gas detectors sense specific gases emitted by combustion.
- Radiant energy (aka flame, light radiation) detectors detect infrared, ultraviolet, or visible radiation (or combinations of) produced by a fire.
- Video image smoke and flame detectors use video cameras and special software that analyzes the images for specific characteristics of heat, flame, or smoke.
- “Other” detectors detect phenomena other than heat, smoke, or flame produced by a fire.

Chapter 6 – Signal Initiation

Automatic Fire Detectors (continued):

- Methods of Operation:
 - Line type detectors sense continuously along a path:
 - Rate-or-rise pneumatic tubing.
 - Projected-beam type smoke detectors.
 - Heat sensitive cable.
 - A spot type detector's detecting element is concentrated at a particular location:
 - Bi-metallic or fusible alloy heat detectors.
 - Specific types of pneumatic heat detectors (HAD).
 - Most standard smoke detectors.

Chapter 6 – Signal Initiation

Automatic Fire Detectors (continued):

- Methods of Operation (continued):
 - Air-sampling type detectors consist of piping through which air samples are continuously drawn to a central location where they are evaluated for a fire signature.
 - Current examples employ either photoelectric (light scattering) or cloud chamber principles.
- Operating Modes:
 - Automatic detectors have two modes of operation:
 - A non-restorable detector is a device whose detecting element is designed to be destroyed in the process of detecting a fire.
 - A restorable detector's sensing element is not ordinarily damaged in the process of detecting a fire. Restoration of the element may be either manual or automatic.

Chapter 6 – Signal Initiation

Automatic Fire Detectors (continued):

- Multimode Detectors are able to respond in more than one way to a fire condition. The modes available are:
 - Combination detectors either respond to multiple fire phenomena (heat, smoke, flame) or employ more than one operating principal to sense one phenomena. Common examples are heat/smoke and rate-of-rise and fixed temperature heat. These devices use an “OR” function, with each sensor operating independently, and provide a single output.
 - Multicriteria detectors can apply logic to make an alarm decision unlike conventional devices which, when a fixed threshold was exceeded, the device went into an alarm state. Decision algorithm devices can be located in the individual detector or within the control panel to which the detectors are connected. Multicriteria detectors produce a single output with a listing that establishes the primary function.
 - Multi-sensor detectors produce multiple outputs and have a listing for each sensing method employed.

Chapter 6 – Signal Initiation

Automatic Fire Detectors (continued):

- Analog Detectors:
 - Analog detectors are any type of fire detector that transmits data continuously or intermittently to the fire alarm control unit for processing.
 - An analog detector does not initiate an alarm; instead, the decision is made at the control panel, based on the data from one or more analog detectors.
 - Some analog detector systems can convert the data into engineering units for display, for example, actual temperature from a heat detector or volume concentration from a gas detector.

Chapter 6 – Signal Initiation

Automatic Fire Detectors (continued):

- Heat Detectors:
 - Heat detectors are the oldest type of automatic fire detection device.
 - Although they are the least expensive of all fire detectors and have the lowest false alarm rate of all automatic detecting devices, they are also the slowest in detecting fires.
 - A heat detector is best suited for:
 - Small confined spaces where high-heat-output fires are expected.
 - In areas where ambient conditions would not allow the use of other fire detection devices.

Chapter 6 – Signal Initiation

Automatic Fire Detectors (continued):

- Heat Detectors (continued):
 - Fixed-temperature heat detectors are designed to initiate an alarm when the temperature of the operating element reaches a specific point.
 - The ambient air temperature at the time of alarm is usually considerably higher than the rated temperature of the detector because of the time it takes for the temperature of the operating element to increase to its set point, a condition known as thermal lag.
 - Fixed-temperature detectors include a large range of operating temperatures for operation in areas normally subject to high ambient (non-fire) temperatures.
 - Heat detectors are required to be marked with their response time index (RTI), which is the quantification of the rate of heat transfer from the ceiling jet to the detector-sensing element per unit of time. This provides an indication of the speed of response of the heat detector for fire modeling purposes.

Chapter 6 – Signal Initiation

Automatic Fire Detectors (continued):

- Heat Detectors (continued):
 - Non-restorable fusible element-type detectors utilize a eutectic metal operating element that rapidly melts at a predetermined temperature.
 - This is the basis for most older style fusible link sprinkler heads.
 - The elements are non-restorable because melting of the eutectic metal causes operating components to separate and fall away from the sprinkler head.
 - The eutectic metal in an electric heat detector is often used as a solder to secure a spring under tension. When the element melts, the spring action closes contacts and initiates an alarm.
 - Devices using eutectic metals cannot be restored; either the device or its operating element must be replaced following operation.

Chapter 6 – Signal Initiation

Automatic Fire Detectors (continued):

- Heat Detectors (continued):
 - Restorable bimetallic-type detectors utilize two metals with different coefficients of thermal expansion, which are bonded together and then heated.
 - Differential expansion causes bending towards the metal with the lower expansion rate, closing a normally open circuit and initiating an alarm.
 - This bimetallic action is similar to that of a bimetallic thermostat controlling the furnace in a home.
 - With a given bimetal, the width of the gap between the contacts determines the operating temperature of the detector; the wider the gap, the higher the operating temperature.
 - Heat detectors with bimetallic elements are normally self-restoring after operation when the temperature drops below the operating (set) point.

Chapter 6 – Signal Initiation

Automatic Fire Detectors (continued):

- Heat Detectors (continued):
 - Various types of line-type heat detectors have been developed as alternatives to spot-type fixed-temperature heat detection, such as continuous line-type heat-sensitive cable detection.
 - This detector used a pair of steel wires in a normally open circuit. The wires, under tension, are enclosed in a sheath to form a single cable assembly. When the temperature set point is reached, the insulation on the cables melts, the wires make contact, and an alarm is initiated.
 - The fused section of cable must be replaced following an alarm to restore the system.
 - A distance meter can be fitted to this system to determine the location of a short-circuited section of the cable to facilitate repairs if damaged or replacement after a fire.

Chapter 6 – Signal Initiation

Automatic Fire Detectors (continued):

- Heat Detectors (continued):
 - A similar alarm device utilizing a semiconductor material and a stainless-steel capillary tube can be used when mechanical stability is a factor in heat detection.
 - The capillary tube contains a coaxial center conductor separated from the tube wall by a temperature sensitive semiconductor material. Under normal conditions, a small current flows in the circuit. As the temperature increases, more current flows and the alarm is initiated.
 - Another line-type heat detector consists of a central fiber optic core which becomes cloudy when exposed to heat, attenuating light that has passed down the fiber. Either a light reduction at the far end, or backscatter at the source end is used to indicate a fire.
 - The backscatter system can also detect the location of the fire by measuring the time between the transmission of the pulse and its return from the cloudy section.

Chapter 6 – Signal Initiation

Automatic Fire Detectors (continued):

- Heat Detectors (continued):
 - Rate compensation detectors are designed to respond when the temperature of the surrounding air reaches a predetermined level, regardless of the rate of temperature rise.
 - This type of detector provides for accurate alarm initiation regardless whether it is exposed to a slow or fast temperature rise.
 - The detector is also self-restoring when the ambient temperature drops to some point below the operating point.

Chapter 6 – Signal Initiation

Automatic Fire Detectors (continued):

- Heat Detectors (continued):
 - Rate-of-rise type detectors are designed to operate more rapidly to flaming fires when the temperature rise exceeds a predetermined value, typically around 12 to 15 degrees per minute.
 - Rate-of-rise detectors are designed to compensate for normal changes in air temperature, less than 12 degrees per minute, that would be expected under non-fire conditions.
 - Most spot-type rate-of-rise detectors are equipped with a fixed-temperature backup feature in the event that the temperature rises more slowly than 15 degrees per minute. This feature will still cause the detector to operate when the temperature has reached a predetermined fixed point.
 - Rate-of-rise detectors are installed in the same manner as fixed temperature detectors.

Chapter 6 – Signal Initiation

Automatic Fire Detectors (continued):

- Heat Detectors (continued):
 - Sealed pneumatic line-type detectors are a special application fixed temperature heat detector which consists of a capillary tube containing a special salt combined with hydrogen gas.
 - At normal temperatures, most of the hydrogen gas is held in the porous salt and the pressure in the tube is low. As the heat increases the pressure in the tube increases, eventually tripping a diaphragm switch and initiating an alarm.
 - A second pressure switch monitors the tube for low pressure.

Chapter 6 – Signal Initiation

Automatic Fire Detectors (continued):

- Heat Detectors (continued):
 - Thermoelectric effect detectors are thermocouple devices that produce electrical voltage in response to an increase in temperature. The voltage is monitored by the control unit.
 - These detectors are no longer manufactured but may still be found in service.
 - Most modern system-connected heat detectors use a heat sensing element called a thermistor, which increases electrical resistance with rising temperature.
 - These devices are able to respond in either a fixed-temperature or rate-of-rise mode or both depending on the control equipment. They can also operate as analog sensors sending data to the fire panel with signals converted to actual temperature readings.

Chapter 6 – Signal Initiation

Automatic Fire Detectors (continued):

- Smoke Detectors:
 - A smoke detector will detect a fire much more rapidly than a heat detector.
 - Smoke detectors are identified by their operating principal, most commonly ionization and photoelectric.
 - Typically, ionization detectors react more rapidly to high-energy (fast-flaming) fires because these fires produce large numbers of smaller smoke particles.
 - Photoelectric detectors respond faster to the smoke generated by low-energy (smoldering) fires, because these fires typically produce more larger smoke particles.
 - However, each type of detector is subjected to, and must pass, testing under the same fire conditions for listing by testing laboratories.

Chapter 6 – Signal Initiation

Automatic Fire Detectors (continued):

- Smoke Detectors (continued):
 - Smoke detectors can control the spread of smoke in the following ways:
 - By preventing recirculation of smoke within a building by the mechanical ventilation system.
 - By selective application of exhaust mechanisms to remove smoke from a building.
 - By selective operation of equipment to pressurize smoke compartments.
 - By closing of doors to seal off the openings in smoke compartments.

Chapter 6 – Signal Initiation

Automatic Fire Detectors (continued):

- Smoke Detectors (continued):
 - Ionization-type smoke detectors use a small amount of radioactive material in the sensing chamber to ionize the atmosphere, rendering the air conductive, and permitting a current flow between two charged electrodes.
 - When smoke particles enter the chamber, they decrease the conductance of the air by attaching themselves to the ions, causing a reduction in ion mobility. The detector responds when the conductance is below a predetermined level.
 - Strict government licensing requirements ensure that there are no radiation hazards from ionization-type smoke detectors.

Chapter 6 – Signal Initiation

Automatic Fire Detectors (continued):

- Smoke Detectors (continued):
 - Photoelectric-type smoke detectors utilize a light beam within the detector. The suspended smoke particles generated during the combustion process affect the propagation of the light beam passing through the air.
 - This effect can be utilized to detect the presence of a fire in two ways:
 - Obscuration of light intensity over the beam path.
 - Scattering of the light beam from its path of travel.

Chapter 6 – Signal Initiation

Automatic Fire Detectors (continued):

- Smoke Detectors (continued):
 - Detectors that utilize the light obscuration principal consist of a light source, a light-beam-collimating system (to make the rays of light parallel), and a photosensitive device, all arranged in a straight line.
 - Dense smoke obscuring part of the beam or less-dense smoke obscuring more of the beam reduces the amount of light reaching the photosensitive device, initiating the alarm.
 - Most light obscuration smoke detectors are of the projected beam type and used to protect large open areas such as atriums.
 - Mirrors may be utilized to determine the area of coverage by directing the beam over a desired path. Mirrors must be used in accordance with the manufacturer’s instructions.
 - The effects of smoke stratification shall be evaluated when locating the detectors.

Chapter 6 – Signal Initiation

Automatic Fire Detectors (continued):

- Smoke Detectors (continued):
 - Detectors that utilize light scattering involves the light being reflected or refracted by smoke particles.
 - Light scattering smoke detectors are normally of the spot type and contain a light source and a photosensitive device arranged so that the light does not normally fall onto the photosensitive device.
 - When smoke particles enter the light path, light strikes the particles and is scattered onto the photosensitive device, causing the detector to respond.

Chapter 6 – Signal Initiation

Automatic Fire Detectors (continued):

- Smoke Detectors (continued):
 - In cloud chamber smoke detectors, an air sample from a protected space containing sub-micrometer size smoke particles is drawn through a humidifier, where it is brought to 100 percent humidity. The sample then passes to an expansion chamber where the pressure is reduced with a vacuum pump, causing condensation of water on the particles. The droplets quickly grow to a visible size.
 - A light beam passing through the cloud of water droplets is used to measure the concentration of droplets formed. The output voltage from the light receiver is directly proportional to the number of droplets.
 - The cloud chamber uses a mechanical valve and switching arrangement to allow sampling from up to four detection zones, with as many as 10 sampling heads per zone. Each zone is sampled once per second for 15 seconds; all four zones are sampled each minute.

Chapter 6 – Signal Initiation

Automatic Fire Detectors (continued):

- Smoke Detectors (continued):
 - Air-sampling smoke detectors sample the air from a protected area and are capable of protecting large areas because of their inherent sensitivity. In addition, the detectors can be used in areas of high air-change rates which would interfere with the operation of other types of smoke detectors.
 - The detectors operate by drawing air through a pipe network with an air-aspirating fan in the detector assembly. Air samples are illuminated with a high-intensity strobe light or laser diode, which causes smoke particles to reflect light to a solid-state photo receiver.
 - The detector provides independent programmable levels of alarms to indicate different levels of fire conditions.
 - Cloud chamber and air-sampling smoke detectors can be set to much higher sensitivities than other smoke detectors, because they are unaffected by air velocity, temperature or humidity conditions.

Chapter 6 – Signal Initiation

Automatic Fire Detectors (continued):

- Smoke Detectors (continued):
 - Air duct smoke detectors are used to prevent the recirculation of smoke from fire within HVAC systems, or the spread of smoke that might be drawn into the system from a room fire.
 - Air duct smoke detection is not a substitute for an area smoke detector or early warning detection system, and it is not a replacement for a building's regular fire detection system. There are numerous limitations to the use of these detectors.
 - Air duct smoke detectors must be listed for the purpose and for the air velocities expected.
 - Design of an air duct smoke detector is based on either ionization, photoelectric, or cloud chamber operating principles.

Chapter 6 – Signal Initiation

Automatic Fire Detectors (continued):

- Smoke Detectors (continued):
 - They must be securely installed in such a manner that they obtain a representative sample of the air stream as follows:
 - Rigid mounting of the detector within the duct without the use of sampling tubes.
 - Rigid mounting to the interior wall of the duct, with the sensing element protruding into the duct.
 - Placement outside the duct, with rigidly mounted sampling tubes protruding into the duct.
 - Use of a projected light beam through the duct.

Chapter 6 – Signal Initiation

Automatic Fire Detectors (continued):

- Gas-Sensing Fire Detectors:
 - Gas-sensing fire detectors are designed to respond to gases that are not normally present, or are present in higher concentrations, during a fire condition. Examples of these gases are H₂O, CO, CO₂, HCL, HCN, HF, H₂S, NH₃, and various oxides of nitrogen. With the exception of water vapor, CO and CO₂, most of the evolved gases in a fire are fuel-specific and not associated with a sufficiently large number of fuels to be usable for general purpose detection.
 - These detectors can operate with simple sensors such as semiconductors or a catalytic element, or more complex apparatus, such as a non-dispersive infrared absorption or electrochemical cells.

Chapter 6 – Signal Initiation

Automatic Fire Detectors (continued):

- Video Image Detectors:
 - Video image detectors consist of common video cameras equipped with frame capture and analysis systems and software that can recognize fire-related images such as flames and smoke. Heat can also be detected by including heat-sensitive panels within the view of the camera.
 - Video image smoke detection systems and all the components thereof, including hardware and software, shall be listed for the purpose of smoke detection.
 - Video signals generated by these systems shall be permitted to be transmitted to other systems for other uses only through output connections provided specifically for that purpose by the video system manufacturer.

Chapter 6 – Signal Initiation

Automatic Fire Detectors (continued):

- Radiant Energy-Sensing Fire Detectors:
 - Flame detectors and spark/ember detectors are the two basic forms of radiant energy-sensing fire detectors. They are used to react to combustion in both the gas phase and solid phase. Flame detectors are generally installed to detect combustion in the gas (flaming) phase. Spark/ember detectors are employed to sense combustion in the solid (spark/ember) phase, normally intended for dark environments.
 - Flame detectors respond to radiant energy within the visible, infrared, or ultraviolet spectrums.
 - Due to their fast detection capabilities, flame detectors are normally only used in high-hazard areas such as fuel-loading platforms, industrial process areas, hyperbaric chambers, high-ceiling areas, and atmospheres in which explosions or very rapid fires may occur.

Chapter 6 – Signal Initiation

Automatic Fire Detectors (continued):

- Radiant Energy-Sensing Fire Detectors (continued):
 - There are three general types of flame detectors:
 - Infrared (IR)
 - Ultraviolet (UV)
 - Combination (IR/UV)
 - Video detectors can also respond to flames as well as smoke depending on the video analysis software. They normally respond to flames in the visible wavelengths.
 - Flame detectors must be able to “see” the fire. They must not be blocked by objects placed in front of them.

Chapter 6 – Signal Initiation

Automatic Fire Detectors (continued):

- Radiant Energy-Sensing Fire Detectors (continued):
 - Infrared-type flame detectors are basically a filter and lens system that screens out unwanted wavelengths and focuses the incoming energy onto a photovoltaic or other type of cell sensitive to infrared energy.
 - IR flame detectors can respond to the total IR component of the flame alone or a combination of IR with flame flicker in the 5-to-30Hz frequency to minimize alarms from hot surfaces where there is no flame.
 - IR detectors based on total IR radiation can be subject to interference from sunlight. This issue can be minimized in two ways; by using specific wavelength filters or by using two detection circuits to mask sunlight effects. In most cases flame flicker sensor circuits are the preferred method of dealing with both solar and man-made interference.
 - IR detectors typically observe a conical volume of approximately 15 to 170 degrees.

Chapter 6 – Signal Initiation

Automatic Fire Detectors (continued):

- Radiant Energy-Sensing Fire Detectors(continued):
 - Ultraviolet-type flame detectors utilize a sensing element that can be either a solid-state device, such as silicon carbide or aluminum nitride, or a gas filled tube in which gas ionized by UV radiation becomes conductive, initiating an alarm.
 - UV detectors operate in the range of 0.17 to 0.30 micrometers, making them essentially insensitive to both sunlight and artificial light.
 - UV detectors typically have viewing angles of 90 to 180 degrees.
 - Ordinary glass blocks UV light, so the windows through which the elements look is quartz. There have been instances in which a broken lens has been replaced with a glass lens rendering the flame detector blind.

Chapter 6 – Signal Initiation

Automatic Fire Detectors (continued):

- Radiant Energy-Sensing Fire Detectors (continued):
 - The combination of UV and IR sensing has been applied to aircraft hangers and hyperbaric chambers. These specific applications utilize devices that initiate an alarm when there is a preset deviation from the prescribed ambient UV/IR discrimination level in conjunction with a signal from a continuous wire overheat detector.
 - Flame detector sensitivities are usually expressed in terms of the specific size of fires that can be detected at a specific distance, for example, a 1-foot-square pan of gasoline at 50 feet. Additionally, they are supplied with maps of their field of view along two axes to assist in their positioning.
 - Flame detectors are frequently used in conjunction with various types of fire suppression systems.

Chapter 6 – Signal Initiation

Automatic Fire Detectors (continued):

- Radiant Energy-Sensing Fire Detectors (continued):
 - Spark/ember detectors are designed to respond to passing sparks or flame fronts in ducts.
 - One specific application for these detectors is in textile mills. The detectors do not contain a flame flicker circuit but scan for glowing lint fibers in air ducts that might cause fires in the downstream filters. The detector turns on a water spray that extinguishes the glowing fiber before it reaches the filter.

Chapter 6 – Signal Initiation

Alarm Systems and Fire-Extinguishing Systems:

Fire alarm systems are also used to actuate fire-extinguishing (suppression) systems. Known as releasing service fire alarm systems, these detection systems provide control inputs for a fire suppression system with a prescribed sequence of operation as well as outputs for other signaling and notification.

- Releasing service fire alarm systems used for automatic or manual activation of a fire suppression system shall be listed for releasing service.
- Releasing devices (solenoid, relay) shall be listed for use with releasing service control units.
- Each releasing device shall be monitored for integrity (supervised).
- Supervision of off-normal conditions that would prevent operation of the system and their return to normal control is also provided.
- Fire alarm control units that monitor fire-extinguishing systems but do not automatically or manually actuate the fire-extinguishing system need not be listed as releasing service fire alarm systems.

Chapter 6 – Signal Initiation

Alarm Systems and Fire-Extinguishing Systems (continued):

- Types of Fire Extinguishing Systems:
 - Wet pipe automatic sprinkler system
 - Pre-action automatic sprinkler system
 - On-off (multicycle) automatic sprinkler system
 - Dry pipe automatic sprinkler system
 - Standpipe and hose system
 - Clean-agent extinguishing system
 - Carbon dioxide extinguishing system
 - Dry or wet chemical extinguishing system
 - Foam-water sprinkler and spray extinguishing system
 - Water mist extinguishing system

Chapter 6 – Signal Initiation

Alarm Systems and Fire-Extinguishing Systems (continued):

- Functions of Alarm and Supervisory Signals:
 - A sprinkler system with a waterflow alarm serves two functions:
 - Notification of building occupants and first responders of a fire.
 - Extinguishment or control of the fire until first responders arrive.
 - It is vital to have the fire-fighting forces notified immediately to complete extinguishment.
 - Waterflow devices initiate an alarm for any condition that causes water to flow through the system, which may include frozen or broken pipes.
 - In addition to waterflow devices, sprinkler systems are equipped with devices that signal abnormal conditions that could make the system inoperative or ineffective.

Chapter 6 – Signal Initiation

Alarm Systems and Fire-Extinguishing Systems (continued):

- Waterflow Alarm and Supervisory Signal Service:
 - Waterflow is to be initiated within 90 seconds after any flow of water equal to, or greater than, that from a single sprinkler of the smallest orifice installed in the system.
 - Movement of water waste, surges, or variable pressure shall not cause an alarm.
 - Most flow switches incorporate a pneumatic retard or other component to provide an adjustable delay.
 - Sprinkler waterflow and supervisory devices shall be designed and installed such that they cannot be readily tampered with. This provision specifically includes junction boxes installed on the outside of buildings to facilitate access to initiating-device circuits.
 - No more than five waterflow switches are permitted to be connected to a single initiating-device circuit to produce the same alarm signal.
 - No more than twenty supervisory signal-initiating devices are permitted to be connected to a single initiating-device circuit to produce the same supervisory signal.

Chapter 6 – Signal Initiation

Alarm Systems and Fire-Extinguishing Systems (continued):

- Waterflow Alarm and Supervisory Signal Service (continued):
 - Generally, the required conditions essential to the operation of sprinkler systems should be supervised, except for those conditions related to the supply of water controlled by a municipality or public utility.
 - Types of supervisory conditions monitored (not all inclusive):
 - Water supply control valves
 - Low water level in water supply tanks
 - Low temperature in water supply tanks or ground-level reservoirs
 - High or low water level and pressure in pressure tanks
 - High or low air pressure in dry pipe sprinkler systems
 - Failure of electric power supply to fire pumps
 - Automatic operation of fire pumps

Chapter 6 – Signal Initiation

Guard's Tour Supervisory Service:

Guard's tour (or watchman's) service dates to the 19th century and was especially prevalent in the textile mills of New England. Guards would walk an hourly tour of a building in the overnight hours looking for fires and other problems. To ensure that the guard made his rounds, a recording system was instituted, consisting of either stationary clocks at selected locations used to mark a card, or a portable clock carried by the guard with keys at selected locations. The keys were inserted into the portable clock to make a mark on an internal card.

- Guard services generally serve three purposes in protecting a property against fire loss; protecting the property at times when occupants are not present, facilitating and controlling the movement of persons into, out of, and within the property, and carrying out procedures for the orderly conduct of some operations on the property.
- Guard supervisory service designed to continuously report the performance of a guard are found in connection with local signaling service, central station service, and proprietary supervising station service.

END OF PERIOD 1 - MODULE 3